

# VF66

## TOYO INTELLIGENT INVERTER

### EIP66-Z Operating Manual

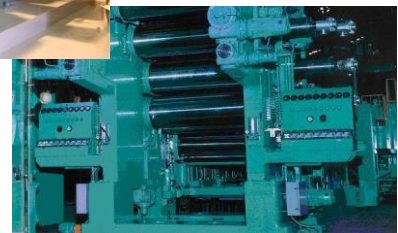



# Preface

Thank you very much for choosing our inverter optional board.

This manual describes handling of the optional board EIP66-Z designed for VF66 inverter. Please read this manual thoroughly to use EIP66-Z properly.

This manual describes the terminal block functions of EIP66-Z board, wiring, switch settings and VF66 inverter settings. For the EtherNet/IP communication functions, refer to "[EIP66-Z Communication Protocol Manual](#)."

To use various functions according to intended use as well as the inverter functions, read the operating instructions of VF66 inverter main unit or dedicated manual thoroughly before use.

The logo for EtherNet/IP, featuring the text "EtherNet/IP" in a bold, blue, sans-serif font. The "N" in "Net" is stylized with a yellow diagonal slash. A small "TM" trademark symbol is located at the top right of the "P".

# Be Sure To Read This Before Use

## Safety Notice

To use the EIP66-Z correctly, be sure to completely read this manual and all other attached documents before installation, operation, maintenance, and inspection. You need to have a good knowledge of equipment, safety information, and all notices before using the EIP66-Z. Read also the operating instructions of VF66 inverter main unit and other related manuals thoroughly before use for safe operations.

In this manual, safety notices are ranked as "Danger," "Warning," and "Caution."



When improper use may cause a dangerous situation, and death or serious injury may result.



When improper use may cause a dangerous situation, medium-level or minor injury may result, and only physical damage may result. However, it can cause serious results depending on the situation. Cautions described in this manual are all important. Be sure to observe them.



## **CAUTION** [Installation]

- Do not use the product if it is found damaged or deformed in unpacking.  
It may cause failure/malfunction.
- Do not put a flammable material near the product.  
It may catch fire.
- Do not give a shock to the product by dropping or toppling it.  
It may cause failure/damage to the product.
- Do not install an optional board with damage or missing part to perform operations.  
It may cause injury.



## **WARNING** [Wiring]

- Check that the input power is turned off before wiring.  
Otherwise, electric shock/fire may result.
- After turning off the power, wait at least ten minutes before opening the inverter front cover.
- Be sure to connect a ground wire.  
Otherwise, electric shock/fire may result.
- Let an electrical engineering technician do the wiring work.  
Otherwise, electric shock/fire may result.
- Be sure to install the main unit before wiring.  
Otherwise, electric shock/fire may result.



## CAUTION [Wiring]

- Be sure to attach and lock the communication cable and connector.  
Otherwise, failure/malfunction may result.



## WARNING [Operation]

- Be sure to attach the inverter front cover before turning on the input power.  
Do not remove the cover while the inverter is energized.  
Ignoring this may cause electric shock.
- Do not operate the switches with wet hands.  
Ignoring this may cause electric shock.
- While the inverter is energized, do not touch the inverter terminals even when the inverter is stopped.  
Ignoring this may cause electric shock.
- Resetting an alarm with the operation signal input causes a sudden restart.  
Perform resetting after making sure that the operation signal is off.  
Otherwise, you may be injured.
- The inverter operation setting is available from low to high speed. Check the allowable range of motor or machine carefully before starting operation.  
Otherwise, injury/failure/damage may result.



## CAUTION [Operation]

- Do not touch the inverter radiation fin or discharge resistor because it can be very hot.  
Ignoring this may cause burn injury.



## WARNING [Maintenance/inspection and part replacement]

- Be sure to turn off the power before performing inspection.  
Otherwise, electric shock/injury/fire may result.
- Only the specified person must perform maintenance/inspection and part replacement.  
Use an insulated tool for maintenance/inspection.  
Otherwise, electric shock/injury may result.



## CAUTION [Others]

- Never modify the product.  
Otherwise, electric shock/injury may result.



## CAUTION [General cautions]

Some figures in this manual are shown with the cover or safety shield removed for the purpose of detailed descriptions. However, for actual operations, be sure to attach the specified cover or safety shield and follow the instructions in this manual.

Note that these safety precautions and specifications described in each manual are subject to change without notice.

# Contents

Be Sure To Read This Before Use.....	4
Safety Notice.....	4
CHAPTER 1 Function Overview.....	7
CHAPTER 2 Basic Specifications.....	8
2. 1 Multifunction Input Terminal Specifications.....	8
2. 2 Analog Input/Output Terminal Specifications.....	9
2. 3 PG Input/Output Terminal Specifications.....	9
2. 4 EtherNet/IP Communication Function Connector/Terminal Specifications.....	10
2. 5 EtherNet/IP Communication Specifications.....	10
2. 6 Others.....	11
CHAPTER 3 Board Description.....	12
3. 1 Part Names.....	12
3. 2 EIP66-Z Switches.....	13
3. 3 How to Mount.....	14
3. 4 LED.....	19
CHAPTER 4 Multifunction Input.....	21
4. 1 Multifunction Input.....	21
CHAPTER 5 Analog Input/Output Function.....	24
5. 1 Analog Input (2).....	24
5. 2 Analog Input (2) Gain/Offset Adjustment.....	25
5. 3 How to Use Analog Input (2).....	27
5. 4 Analog Output (2).....	30
5. 5 Analog Output (2) Gain/Offset Adjustment.....	31
CHAPTER 6 PG Input/Output Function.....	34
6. 1 PG Input Signal.....	34
6. 2 PG Output Signal.....	36
CHAPTER 7 EtherNet/IP Communication Function.....	37
7. 1 EtherNet/IP Connection.....	37
7. 2 EtherNet/IP Communication Function Setting.....	38

# CHAPTER 1 Function Overview

EIP66-Z is used with the substrate (VFC66-Z) in a VF66B inverter. EIP66-Z is equipped with the EtherNet/IP adapter function (slave station), analog input/output function, multifunction input and PG input/output function.

EtherNet/IP is a public network standard, and the specification and protocol are made public by ODVA (Open DeviceNet Vendor Association, Inc.) to provide mutual compatibility between the devices of the same type by multiple vendors.

The EIP66-Z EtherNet/IP communication function allows users to input a command related to operation, speed, torque, etc. to the VF66 inverter or monitor the situations including the inverter operation/protection status, current and voltage. In addition, reading/rewriting of inverter settings and reading of traceback data, protection history and monitoring data are available. For the EtherNet/IP communication functions, refer to "EIP66-Z Communication Protocol Manual." This function can also be used as an input/output signal of the internal PLC function of the VF66 inverter. For the internal PLC function, refer to the VF66 PC Tool manual.



## **CAUTION** [Safety precautions]

Read this manual thoroughly before use for proper handling.

Our inverter is not designed/manufactured for the devices or systems used in a life-threatening situation.

Do not use this inverter for special use, such as riding mobile object, medical care, aerospace, nuclear power control, submarine repeater/system, etc.

This inverter is manufactured under stringent quality control; however, install safety equipment to avoid a serious accident for the important facility which may put human lives in danger by failure of the inverter

or the facility to which a serious loss is caused by failure of the inverter.

Contact us to use this product for the load other than three-phase AC motors.

Electrical work is required for this inverter. Let an electrical engineering technician do the work.

# CHAPTER 2 Basic Specifications

## 2. 1 Multifunction Input Terminal Specifications

### Multifunction input

	Terminal name	Usage	Description
EIP66-Z terminal block TB1	PS (2 terminals)	+12 V power supply terminal	Outputs a direct voltage of +12 V.
	G (2 terminals)	GND terminal	Do not connect G terminal to the ground terminal. Do not bring PS and G terminals into contact or connect them.
	MI6	Multifunction input terminal (6)	(Maximum input voltage 24 VDC/maximum input current 3 mA) The same operation as VF66 inverter console is enabled by inputting a signal to the multifunction input terminal. [Under the default condition, the followings are set by the VF66 inverter setting parameter: Area c.] <ul style="list-style-type: none"> <li>• Preset speed selection 1 is set for the multifunction input terminal (6).</li> <li>• Preset speed selection 2 is set for the multifunction input terminal (7).</li> <li>• Preset speed selection 3 is set for the multifunction input terminal (8).</li> <li>• Acceleration or deceleration time selection 1 is set for the multifunction input terminal (9).</li> </ul>
	MI7	Multifunction input terminal (7)	
	MI8	Multifunction input terminal (8)	
	MI9	Multifunction input terminal (9)	
			* For more information about multifunction input terminals, refer to the operating instructions of VF66 inverter main unit.

### Multifunction input source/sink mode setting jumper connector

	Connector symbol	Usage	Description
EIP66-Z jumper connector	CN-SO	Source mode	<ul style="list-style-type: none"> <li>• Change the connection of jumper socket to jumper connector to switch between the source and sink modes.</li> <li>• Be sure to turn off the inverter power before changing the connection of jumper socket.</li> </ul> [The source mode is selected in the default condition.]  <ul style="list-style-type: none"> <li>• For the source mode, install a switch, etc. between the multifunction input terminals (6) to (9) and PS terminal to turn ON/OFF.</li> <li>• For the sink mode, install a switch, etc. between the multifunction input terminals (6) to (9) and G terminal to turn ON/OFF.</li> </ul> For more information, refer to CHAPTER 4.
	CN-SI	Sink mode	

## 2. 2 Analog Input/Output Terminal Specifications

### Analog input/output function

EIP66-Z terminal block TB1	Terminal name	Usage	Description
	AIN2	Analog input (2) terminal	<ul style="list-style-type: none"> <li>For the analog input (2) terminal, the input range can be selected from 0 to <math>\pm 10</math> V, 0 to 10 V, and 4 to 20 mA by switching of SW1 and changing of VF66 inverter setting parameter. (For switching of the input range, refer to CHAPTER 5.)</li> <li>The input impedance at analog voltage input is 150 k<math>\Omega</math>.</li> <li>The input resistance at analog current input is 250 <math>\Omega</math>. [The 0 to 10 V input is selected in the default condition.]</li> </ul> * For more information about the analog input (2) terminal, refer to the operating instructions of VF66 inverter main unit.
	AOT2	Analog output (2) terminal	<ul style="list-style-type: none"> <li>For the analog output (2) terminal, the output range can be selected from 0 to 10 V and 0 to <math>\pm 10</math> V (maximum current: 1 mA) by changing of VF66 inverter setting parameter.</li> </ul> [The setting is made so that the inverter output current becomes 5 V/inverter rated current in the default condition.]  * For more information about the analog output (2) terminal, refer to the operating instructions of VF66 inverter main unit.
G2	GND terminal	Do not connect G2 terminal to the ground terminal.	

## 2. 3 PG Input/Output Terminal Specifications

### PG input/output function

EIP66-Z terminal block TB2	Terminal name	Usage	Description
	+12	+12 V power supply terminal	Outputs a direct voltage of +12 V.
	G (3 terminals)	GND terminal	Do not connect G terminal to the ground terminal.
	A	PG input terminal	Inputs A, B, U/Z, V or W signal of 12 V power supply PG (complementary output).
	B		
	U/Z		
	V		
	W		
PGOUT	PG output terminal	Outputs a waveform of frequency divided A signal of PG.	

## 2. 4 EtherNet/IP Communication Function Connector/Terminal Specifications

### Communication function connector specifications (RJ-45 8 poles)

EIP66-Z connector CN3/4	Pin No.	Usage	Description
	1	TX+	Transmission signal line (+)
	2	TX-	Transmission signal line (-)
	3	RX+	Reception signal line (+)
	4	-	Unused
	5	-	
	6	RX-	Reception signal line (-)
	7	-	Unused
	8	-	

### Communication function terminal specifications

EIP66-Z terminal block TB3	Terminal name	Usage	Description
	FG	Safety ground terminal	FG terminal (M4) for CN3/CN4

## 2. 5 EtherNet/IP Communication Specifications

### EtherNet/IP communication specifications

Ethernet	Compliance standard	IEEE802.3i (10BASE-T)/IEEE802.3u (100BASE-TX)
	Transmission speed	10/100 Mbps (automatic switching)
	Communication mode	Full-duplex/half-duplex (automatic switching)
	Connection type	Star/daisy chain connection
	Interface	RJ-45 connector
	Transmission distance (between nodes or node and hub)	Within 100 m (depends on the specification of used cable)
	Connected cable	Shielded twisted pair cable (STP): Category 5 or higher Straight, cross (automatic switching)
	EtherNet/IP	IP address setting
Communication function		Cyclic communication (Implicit message) Message communication (Explicit message)
Vendor ID		178
Product Code		13
Device Type		AC Drive Profile
Product Name		EIP66 Series
ACD function (Address Conflict Detection)		Supported
Conformance test		EtherNet/IP CT-11
EDS file		EIP66 Series 1_0. eds

## 2. 6 Others

---

Other standard specifications conform to the VF66 inverter. For more information, refer to the operating instructions of VF66 inverter main unit.



### **WARNING** [Wiring]

- Check that the input power is turned off before wiring.  
Otherwise, electric shock/fire may result.
- Be sure to turn off the inverter power before changing the connection of jumper socket.  
Otherwise, electric shock/injury/failure/malfunction may result.



### **CAUTION** [Wiring]

- Never connect the G and G2 terminals to a ground.  
Ignoring this may cause failure/damage.
- Do not bring the PS and G terminals into contact or connect them.  
Ignoring this may cause failure/damage.

# CHAPTER 3 Board Description

## 3. 1 Part Names

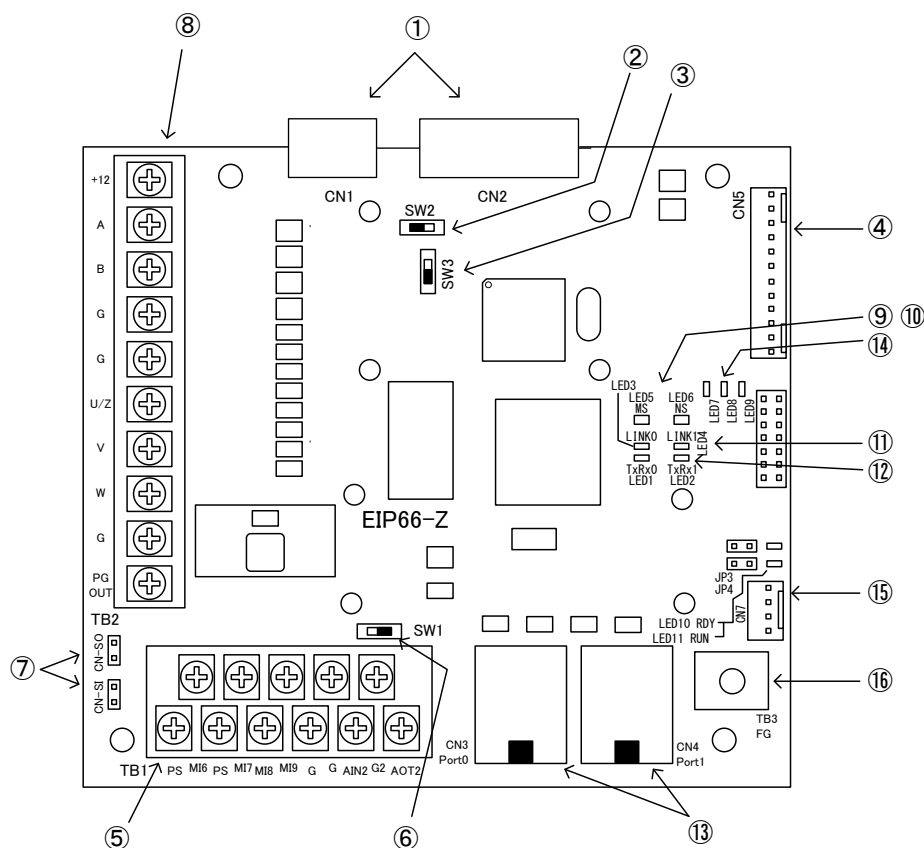

Figure 3. 1 EIP66-Z board

- ① VFC66-Z connector (CN1, CN2)
- ② PG frequency division output switch (SW2)
- ③ PG signal ON/OFF switch (SW3)
- ④ External extension option (for future extension) connector (CN5)
- ⑤ Analog input/output, multifunction input (TB1)
- ⑥ Analog input signal characteristics changeover switch (SW1)
- ⑦ Jumper connector for switching multifunction input signal characteristics (CN-SI, CN-SO)
- ⑧ PG input/output terminal block (TB2)
- ⑨ EtherNet/IP module status (MS) LED (LED5 green/red)
- ⑩ EtherNet/IP network status (NS) LED (LED6 green/red)
- ⑪ EtherNet/IP link (LINK) LED (LED3, LED4 green)
- ⑫ EtherNet/IP transmission and reception (TxRx) LED (LED1, LED2 yellow)
- ⑬ EtherNet/IP communication RJ-45 connector (CN3, CN4)
- ⑭ Status LED (LED7, LED8, LED9)
- ⑮ Maintenance connector, jumper connector, LED (CN7, JP3, JP4, LED10, LED11)
- ⑯ FG terminal block (TB3)

For the connector connected to (4), use a Molex housing: 5051-12 and gold-plated terminal: 2759G or 2759PBG. For the connection and use of CN5, refer to the operating instructions of IOEXT66-Z.

### 3. 2 EIP66-Z Switches

---

Various EIP66-Z functions can be changed using switches.

#### EIP66-Z switch functions

Switch name	Usage	Description
SW1	Analog input (2) signal characteristics changeover switch	Changes the input signal characteristics of analog input (2) terminal. <ul style="list-style-type: none"><li>• 0 to 10 V or 0 to <math>\pm 10</math> V input is available with the switch OFF.</li><li>• 4 to 20 mA input is available with the switch ON.</li></ul> [The switch is set to OFF in the default condition.] * To change the input range, change the setting parameter of VF66 inverter as well. For more information, refer to CHAPTER 5.
SW2	PG frequency division output switch	Changes the output waveform of frequency divided PG signal. <ul style="list-style-type: none"><li>• 1/4 frequency divided signal is output with the switch at 3 side.</li><li>• 1/2 frequency divided signal is output with the switch at 1 side.</li></ul> [The switch is set to 3 side in the default condition.]
SW3	PG signal ON/OFF switch	Turns on/off the PG signal. <ul style="list-style-type: none"><li>• Disables PG signal input with the switch OFF.</li><li>• Enables PG signal input with the switch ON.</li></ul> [The switch is set to ON in the default condition.]



## WARNING [Switches]

- Be sure to turn off the inverter power before turning the switch. Otherwise, electric shock/injury/failure/malfunction may result.

### 3. 3 How to Mount

This board has different mounting methods depending on the model name. Check the board model name before installing the board with following procedure. The board model name is silk-printed at the position shown in Figure 3. 1.

• For EIP66-Z-P1

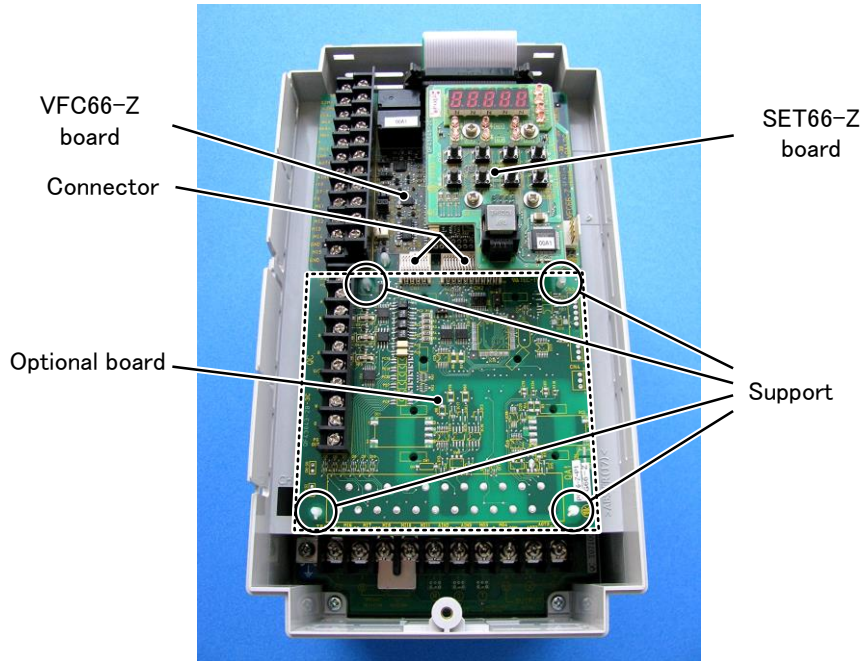

Figure 3. 2 Optional board mounting position (VF66B-2R222)

\* For opening/closing of the inverter front cover, refer to the operating instructions of inverter main unit.

- (1) Before starting to work, check that the inverter power is turned off.
- (2) Mount the EIP66-Z board to the area enclosed by the dotted line in Figure 3. 2 (the figure shows the case of VF66B-2R222, but the same applies to the models with other capacities). If another optional board has already been mounted, remove it according to the following procedure. If another optional board is not mounted, proceed to (6).
- (3) First, remove the SET66-Z board to remove an optional board safely. Remove the four screws encircled in the right figure and pull out the SET66-Z board from the VFC66-Z board.
- (4) Next, release the two connectors between the VFC66-Z board and optional board. Figure 3. 4 (a) shows the state with the connector fixed. As shown in Figure 3. 4 (b), push up the tab to release the connector.
- (5) The supports that fix the optional board to the inverter chassis are located in the four areas encircled in Figure 3. 2. Push the pawl part shown in Figure 3. 5 into the support

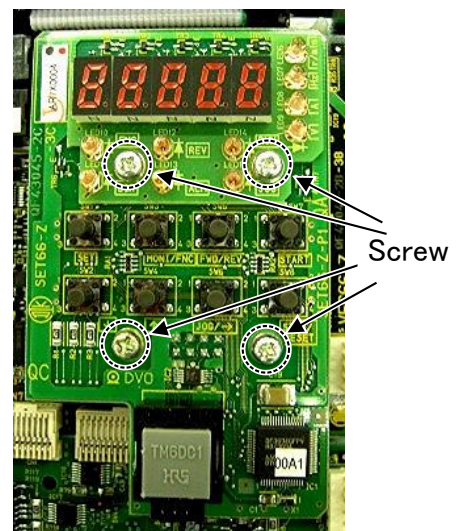
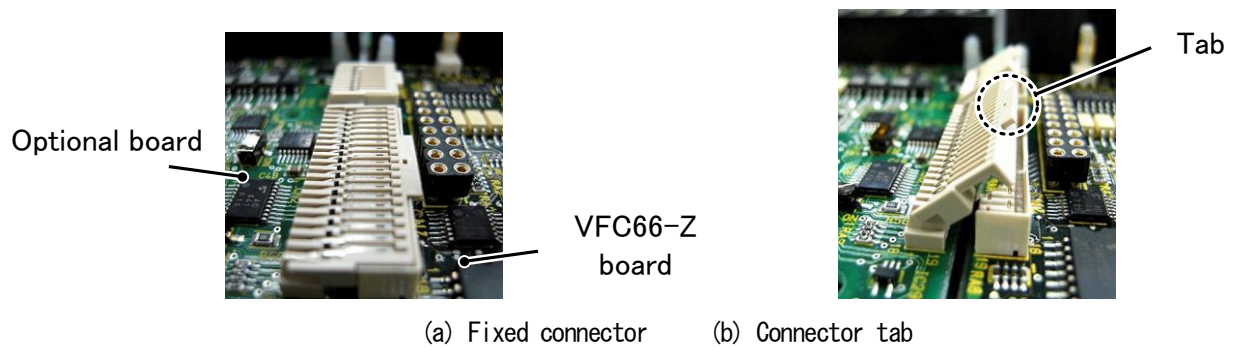

Figure 3. 3 SET66-Z board

and remove the optional board.



(a) Fixed connector (b) Connector tab

Figure 3. 4 Connector

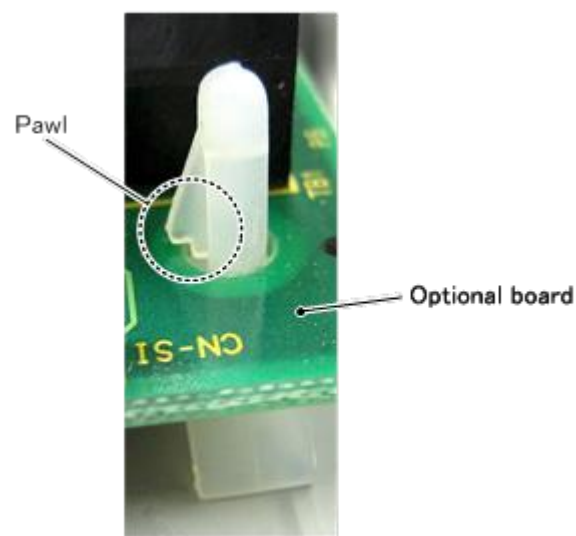

Figure 3. 5 Pawl part of support

- (6) Align the four holes on the EIP66-Z board with the support positions encircled in Figure 3.2, and push the board until the pawl part of the support is hooked to the top of the board as shown in Figure 3.5.
- (7) Fit the EIP66-Z board connectors CN1 and CN2 into the VFC66-Z board connectors CN7 and CN4, respectively, by pushing down the tab as shown in Figure 3.4 (b). Figure 3.4 (a) shows the state with the connector fixed. The moving part of the connector is elastic. Fix it securely to prevent disconnection.
- (8) Reattach the SET66-Z board.
- (9) Reattach the inverter front cover.



## **WARNING** [Attachment/removal]

- Be sure to turn off the inverter power before attaching or removing a board.  
Otherwise, electric shock/injury/failure/malfunction may result.



## **CAUTION** [Attachment/removal]

- Do not attach/remove the connector repeatedly.  
Loosened connection part of the connector may cause problems such as connection failure.
- Do not insert the objects other than the proper fitted object.  
Deformed connection part of the connector may cause problems such as connection failure.

• For EIP66-Z-P2

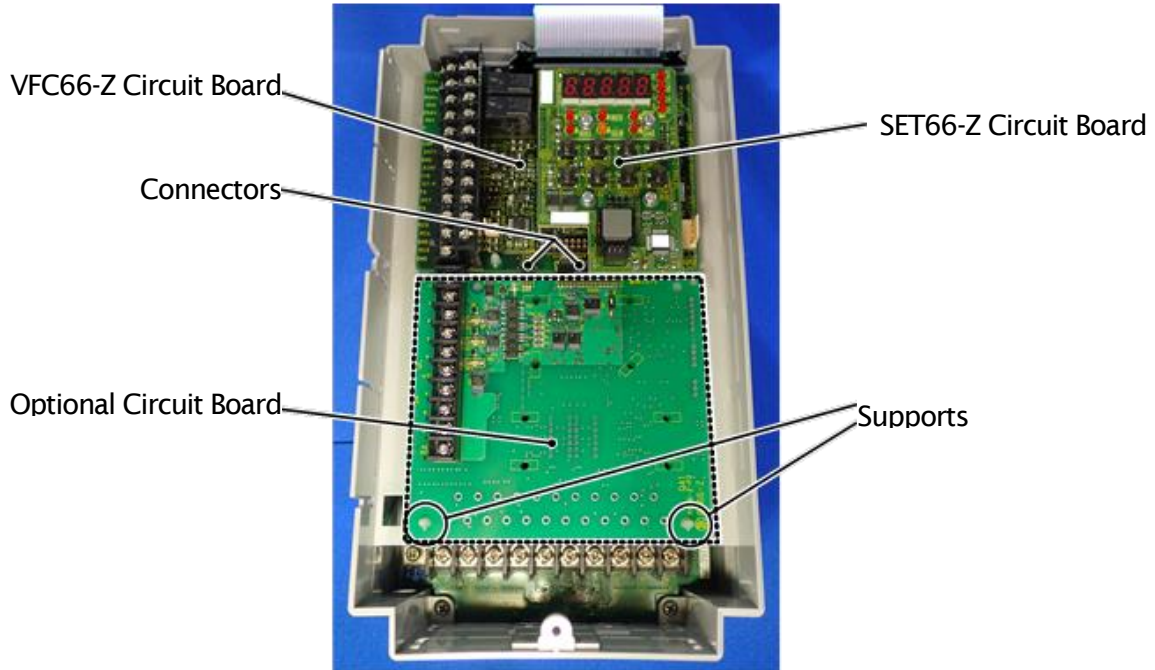

Figure 3.6 EIP66-Z Installation Position (VF66B-2R222)

\*For information about opening and closing the inverter unit cover lid, please refer to the VF66B inverter manual.

- (1) Confirm that the power is off before performing any work.
- (2) Install the EIP66-Z board in the location designated by the dotted lines shown in Figure 3.6. (The figure shows the VF66B-2R222 model, however, the installation location is the same for other models.) If another optional circuit board is already installed, remove it by following the procedure described below. If another optional circuit board is not already installed, skip to (6).
- (3) In order to safely remove the optional circuit board, first remove the SET66-Z board. Remove the 4 screws indicated by the circles in the figure on the right. Pull the SET66-Z board away from the VFC66-Z board in order to detach it.
- (4) 2 board supports are included to mount the optional circuit board to the inverter housing, as indicated by the circles in Figure 3.6. Press down on the board support locking hooks as shown in Figure 3.8 (a) to remove the board. Do not lift the bottom edge of the board too much, the connectors could be damaged.

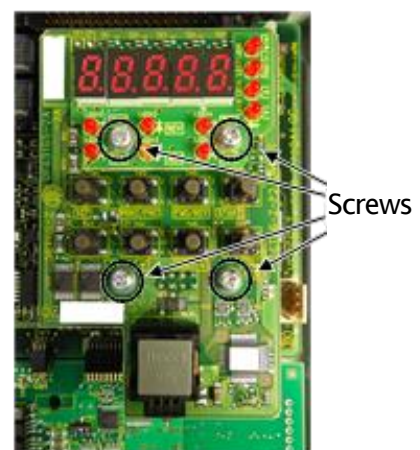

Figure 3.7 SET66-Z Circuit Board

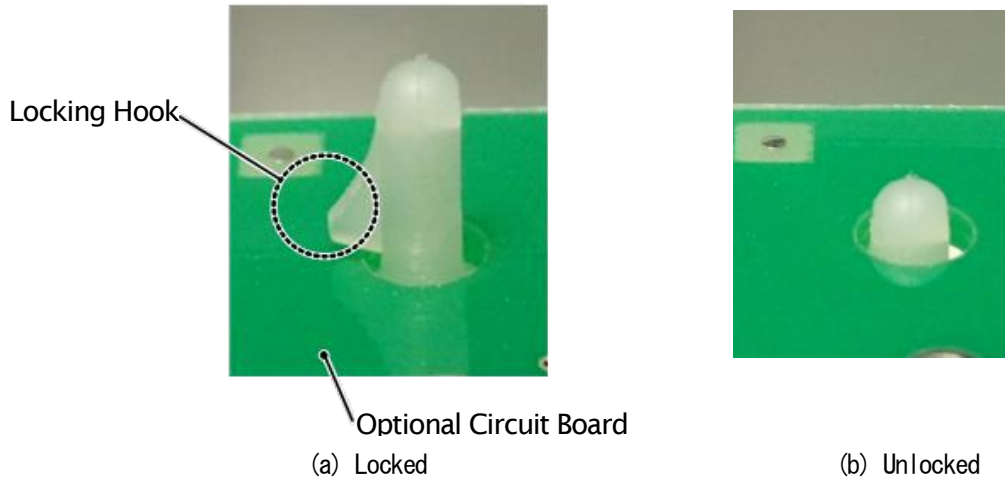

Figure 3.8 Support Locking Hook

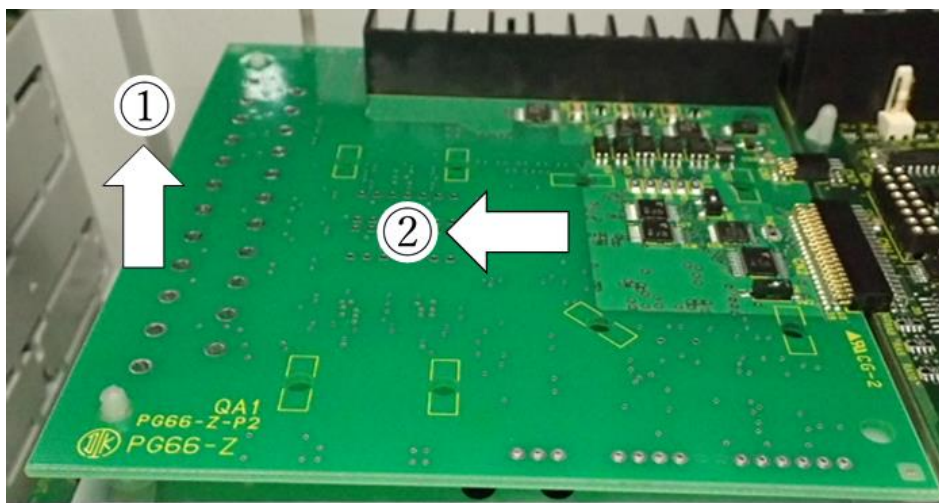

Figure 3.9 Removal of the Optional Circuit Board

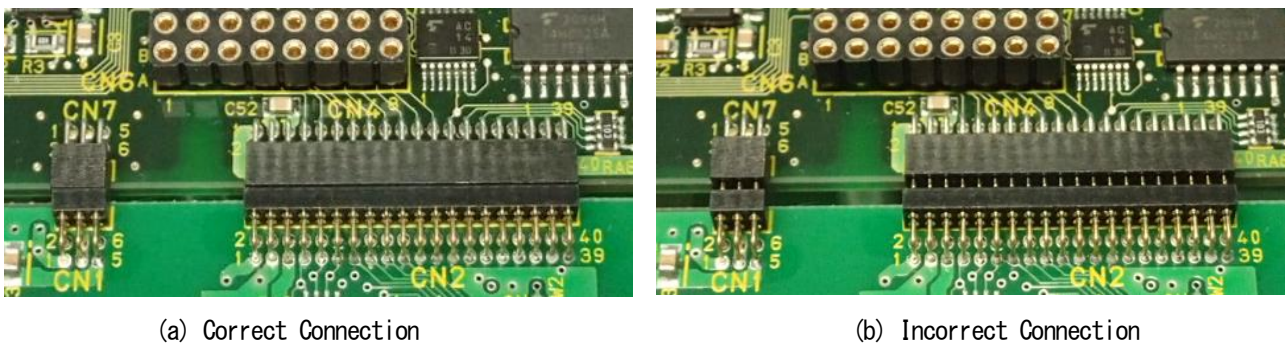



Figure 3.10 Connector

- (5) As shown in Fig. 3.9, lift the bottom edge of the board in the direction of “1” and pull the board away from the VFC66-Z in the direction of “2”.
- (6) As shown in Fig. 3.10 (a), Align the pins of the EIP66-Z board connectors CN1 and CN2 with the VFC66-Z board connectors CN7 and CN4, push the EIP66-Z board to engage with the connectors. If the connectors are not connected properly, there will be a gap between the connectors as shown in Figure 3.10 (b).
- (7) Align the four holes of the EIP66-Z board with the 2 board supports indicated by the circles in Figure 3.6. Push down on the board until the support locking hooks snap into place as shown in Figure 3.8 (a).

- (8) Install the SET66-Z board to its original position.
- (9) Return the inverter unit cover lid to its original position.

 <span style="font-size: 24pt; font-weight: bold; margin-left: 10px;">DANGER</span> [Installation/Removal]
<ul style="list-style-type: none"> <li>● Always confirm that the power is off before installing/removing any circuit boards. Failure to do so may cause an electric shock, personal injury, equipment failure or malfunction.</li> </ul>

 <span style="font-size: 24pt; font-weight: bold; margin-left: 10px;">CAUTION</span> [Installation/Removal]
<ul style="list-style-type: none"> <li>● Avoid excess connection and disconnection of the connectors. The connector mounting area may become loose, leading to problems such as poor connections.</li> <li>● Do not attempt to insert any object other than a compatible connector. The connector mounting area may deform, leading to problems such as poor connections.</li> </ul>

### 3. 4 LED

---

- **LED1 (TxRx0) and LED2 (TxRx1) operation**

Blinks when the EtherNet/IP communication is performed or data is transmitted/received.  
LED1 and LED2 support Port0 (CN3) and Port1 (CN4), respectively.

- **LED3 (LINK0) and LED4 (LINK1) operation**

Lights up when a link is established in the network.  
LED3 and LED4 support Port0 (CN3) and Port1 (CN4), respectively.

- **LED5 (MS) operation**

The module status LED lights up in two colors (green/red) to indicate the device status.  
It indicates whether the device is powered on and the device functions normally.  
The following table defines the status of module status LED.

Status	LED	Description
Power Off	Off	Power is not supplied to the device.
Device Operational	Green	The device functions normally.
Standby	Blinking green	The device has not been set.
Minor Fault	Blinking red	A recoverable error occurs in the device.
Major Fault	Red	An unrecoverable error occurs in the device. Device replacement may be necessary.
Self-Test	Blinking red and green	The device is undergoing self-diagnostic test at power-on.

• **LED6 (NS) operation**

The network status LED lights up in two colors (green/red) to indicate the communication link status. The following table shows the status of network status LED.

Status	LED	Description
Not powered, no IP address	Off	No IP address exists in the device. Or power is not supplied to the device.
No connections	Blinking green	Connection is not established, but IP address is obtained.
Connected	Green	Connection is established.
Connection Timeout	Blinking red	Connection time-out occurs.
Duplicate IP	Red	IP address overlaps with another device.
Self-Test	Blinking red and green	The device is undergoing self-diagnostic test at power-on.

• **LED7 (CPURUN) operation**

While EIP66-Z functions normally, LED7 blinks at intervals of approx. one second. If LED7 does not blink normally after power-on, the following causes are suspected.

- Poor contact between VFC66-Z and EIP66-Z
- Failure of VFC66-Z or EIP66-Z

• **LED8 (COMM) operation**

LED8 lights up while the connection for cyclic communication is established.

When the standard profile is used, it lights up also when the connection for message communication is established.

• **LED9 (ALRM) operation**

LED9 lights up or blinks when a setting error of device occurs. If LED9 lights up or blinks at power-on, the following causes are suspected.

- Instance number setting error (lights up)
- IP address setting error (blinks)
- Conflict of IP addresses detected at start-up (blinks)
- EtherNet/IP communication IC failure (lights up or blinks)

 **CAUTION** [Safety precautions]

- If LED7 does not function normally, it may indicate a failure of EIP66-Z or VFC66-Z.

# CHAPTER 4 Multifunction Input

## 4. 1 Multifunction Input

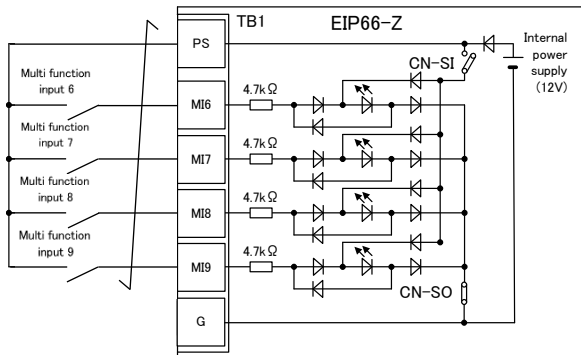

**1. Source mode (use internal power supply)**

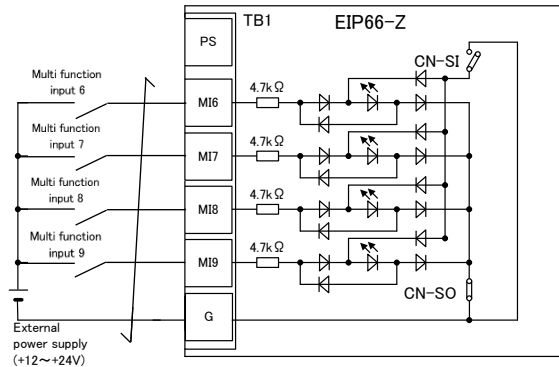

**2. Source mode (use external power supply)**

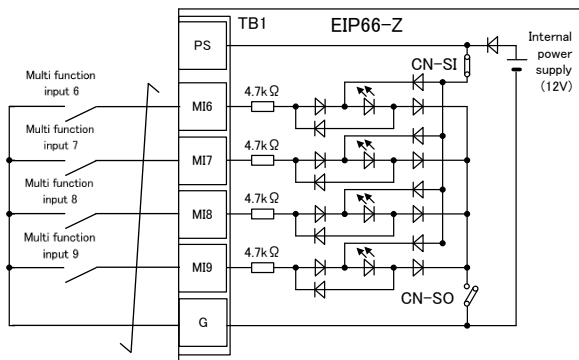

**3. Sink mode (use internal power supply)**

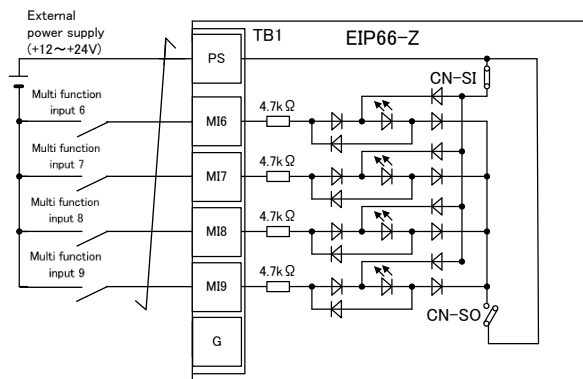

**4. Sink mode (use external power supply)**

Figure 4. 1 Multifunction input connection

EIP66-Z can use the multifunction input of VF66 inverter. The above figures show typical connection methods for multifunction input signals. The maximum allowable voltage is 24 V, and the maximum allowable current per terminal is 3 mA. For the function of each multifunction input terminal, refer to the operating instructions of VF66 inverter main unit.

The source or sink mode can be selected for the multifunction input signal, and the use of internal or external power supply of inverter can be selected for each mode. The source mode is selected in the default condition. A switch between the source and sink modes can be made by inserting the jumper socket to the EIP66-Z board jumper connector CN-SO (source mode) or CN-SI (sink mode).

## Multifunction input related inverter parameters

Display	Description	Selection	Default	Unit
c-00	Multifunction input place selection	0: Terminal block 1: Digital communication option	0: Terminal block	–
c-06	Multifunction input terminal (6) function selection	0: Preset frequency selection 1 (V/f mode) Preset speed selection 1 (induction motor/ED motor vector mode)	0: Preset frequency selection 1	–
c-07	Multifunction input terminal (7) function selection	1: Preset frequency selection 2 (V/f mode) Preset speed selection 2 (induction motor/ED motor vector mode)	1: Preset frequency selection 2	
c-08	Multifunction input terminal (8) function selection	2: Preset frequency selection 3 (V/f mode) Preset speed selection 3 (induction motor/ED motor vector mode)	2: Preset frequency selection 3	
c-09	Multifunction input terminal (9) function selection	3: Acceleration or deceleration time selection 1 4: Acceleration or deceleration time selection 2 5: Frequency UP command (MRH mode) (V/f mode) Speed UP command (MRH mode) (induction motor/ED motor vector mode)	3: Acceleration or deceleration time selection 1	
c-10	Multifunction input terminal (10) function selection	6: Frequency DOWN command (MRH mode) (V/f mode) Speed DOWN command (MRH mode) (induction motor/ED motor vector mode)	4: Acceleration or deceleration time selection 2	
c-11	Multifunction input terminal (11) function selection	7: Frequency hold (V/f mode) Speed hold (induction motor/ED motor vector mode) 8: S-pattern acceleration or deceleration prohibition 9: Maximum frequency reduction (V/f mode) Maximum speed reduction (induction motor/ED motor vector mode) 10: Droop control not operated 11: No function (V/f mode) Speed/torque control selection (induction motor/ED motor vector mode) 12: Forward/reverse operation command selection 13: DC brake command 14: No function (V/f mode) Initial excitation command (induction motor/ED motor vector mode) 15: External failure signal 1 (protection relay 86A operation) 16: External failure signal 2 (protection relay 86A operation) 17: External failure signal 3 (protection relay 86A operation) 18: External failure signal 4 (protection relay 86A operation) 19: External failure signal 1 (protection relay 86A not operated) 20: External failure signal 2 (protection relay 86A not operated) 21: External failure signal 3 (protection relay 86A not operated) 22: External failure signal 4 (protection relay 86A not operated) 23: Traceback external trigger 24: Second setting block selection 25: Emergency stop (Normally close) 26: No function 27: Frequency command terminal block selection (V/f mode) Speed command terminal block selection (induction motor/ED motor vector mode) 28: No function 29: Operation command [reverse] (STARTR) 30: JOG command [forward] (JOGF) 31: JOG command [reverse] (JOGR) 32: Emergency stop (Normally open) 33: Protection reset (RESET) 34: External signal input 1 35: External signal input 2 36: External signal input 3 37: External signal input 4	5: Frequency UP command	

The EIP66-Z multifunction input can be made via EtherNet/IP communication as well as a terminal block. Select either of them with the inverter setting parameter c-00. For more information about the multifunction input via communication, refer to “EIP66-Z Communication Protocol Manual.”

The EIP66-Z multifunction input signal can also be used as an input relay of the internal PLC function of the VF66 inverter. For more information, refer to "EIP66-Z Communication Protocol Manual," operating instructions of VF66 inverter main unit and VF66 PC Tool manual.



## **WARNING** [Wiring]

- Check that the input power is turned off before wiring.  
Otherwise, electric shock/fire may result.
- Be sure to turn off the inverter power before changing the connection of jumper socket.  
Otherwise, electric shock/injury/failure/malfunction may result.



## **CAUTION** [Wiring]

- Never connect the G and G2 terminals to a ground.  
Ignoring this may cause failure/damage.
- Do not bring the PS and G terminals into contact or connect them.  
Ignoring this may cause failure/damage.

# CHAPTER 5 Analog Input/Output Function

## 5. 1 Analog Input (2)

Using the analog input (2) function, an analog signal input to the EIP66-Z board terminal can be used as a speed (or frequency) command, torque command or input value to the internal PLC function.

To use the analog input (2) function, the setting parameter of VF66 inverter main unit shown in the following table needs to be set appropriately. Read also the operating instructions of VF66 inverter main unit. For the internal PLC function, refer to the VF66 PC Tool manual.

Before using the analog input (2) function, adjust gain and offset as described in the following section.

### Inverter setting parameter for analog input (2) signal characteristics

Display	Description	Setting band (selection item)	Default	Unit
G-03	Analog input (2) characteristics selection	0: 0 to $\pm 10$ V 1: 0 to 10 V 2: 4 to 20 mA	1	-

\* Set the parameter to 0 to use the analog input (2) as a torque command. Only the 0 to  $\pm 10$  V input characteristic can be used.

For the analog input (2), input an analog signal to the terminals "AIN2" and "G2" on the EIP66-Z board terminal block TB1 as shown in the following figure. The input analog signal characteristic can be selected from "voltage input of 0 to  $\pm 10$  V," "voltage input of 0 to 10 V" and "current input of 4 to 20 mA" as shown in the above table. Set the parameter appropriately according to the input signal characteristic. Also, set the switch SW1 as shown in the following figures.

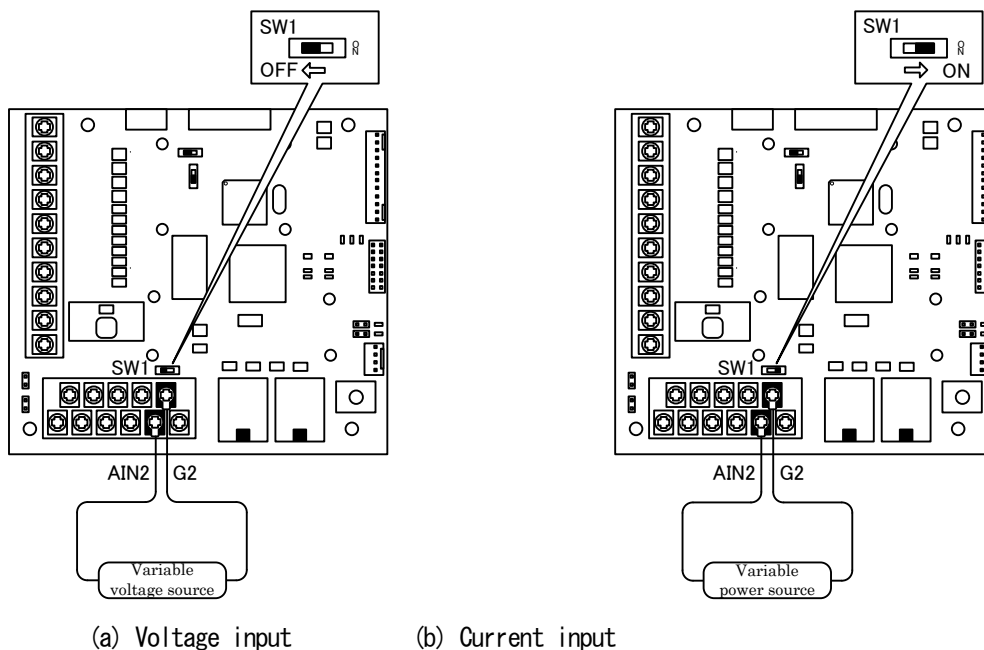

Figure 5. 1 Analog input (2) connection example

## 5. 2 Analog Input (2) Gain/Offset Adjustment

---

Before using the analog input (2), adjust gain and offset. Perform the adjustment at room temperature (25 °C).

Before adjusting gain and offset for the analog input (2), adjust gain and offset for the analog input (1) of VF66 inverter main unit. For how to adjust gain and offset for the analog input (1), refer to the operating instructions of VF66 inverter main unit. The gain and offset for the analog input (1) are adjusted prior to shipment; therefore, further adjustment is not necessary in normal cases.

### Inverter setting parameters related to analog input (2) gain/offset adjustment

Display	Description	Setting band (selection item)	Default	Unit
L-05	Analog input (2) gain	50.00 to 150.00	100.00	%
L-06	Analog input (2) offset	-50.00 to 50.00	0.00	%
S-08	Analog input (2) adjustment	1: Analog input (2) offset adjustment A value of 1000 times the analog input (2) voltage (V): Analog input (2) gain adjustment	-	-

(1) Input characteristics "0 to ±10 V" and "0 to 10 V"



Press the [MONI/FNC] key to enter the FNC (function selection) mode (LED-FNC lights up).



Select "G-03" with the [↑]/[↓] key and confirm it with the [SET] key.

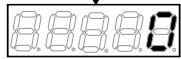

Move the operating digit to the right with the [JOG/→] key and change the value to "0" using the [↑]/[↓] key. Then confirm the value with the [SET] key.

Printed board  
<EIP66-Z>  
terminal block

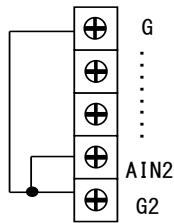

Turn off the inverter power, open the front cover, and then make a short-circuit between the terminals [AIN2], [G] and [G2] on the terminal block of optional printed board <EIP66-Z>.

**CAUTION** [Short-circuit of terminals]

- Be sure to turn off the inverter power before short-circuiting terminals. Otherwise, electric shock may result.



Turn on the power and then press the [MONI/FNC] key to enter the FNC (function selection) mode (LED-FNC lights up). After that, select "S-08" using the [JOG/→]/[↑]/[↓] key and confirm it with the [SET] key.



Change the value to "1040" using the [JOG/→]/[↑]/[↓] key and confirm it with the [SET] key.

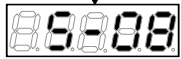

When "S-08" is displayed again, confirm it with the [SET] key.

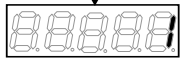

Enter "1" using the [JOG/→]/[↑]/[↓] key and confirm it with the [SET] key.

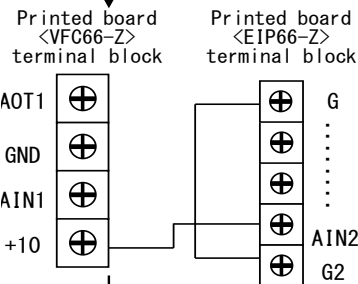

Turn off the inverter power, open the front cover, and then make a short-circuit between the terminals [AIN2] on the terminal block of printed board <EIP66-Z> and [+10] on the terminal block of printed board <VFC66-Z>. Keep the terminals [G] and [G2] on the terminal block of printed board <EIP66-Z> short circuited.

**CAUTION** [Short-circuit of terminals]

- Be sure to turn off the inverter power before short-circuiting terminals. Otherwise, electric shock may result.



Turn on the power and then press the [MONI/FNC] key to enter the FNC (function selection) mode (LED-FNC lights up). After that, select "S-08" using the [JOG/→]/[↑]/[↓] key and confirm it with the [SET] key.



Change the value to "1040" using the [JOG/→]/[↑]/[↓] key and confirm it with the [SET] key.

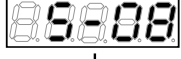

When "S-08" is displayed again, confirm it with the [SET] key.



Measure voltage between the terminals [AIN2] and [G] of printed board <EIP66-Z> using a tester, etc. and enter a value of 1000 times the measured value. If measurement cannot be performed, enter "9930" but it provides lower accuracy.

**CAUTION** [Inter-terminal voltage measurement]

- Be very careful not to touch wires or terminals in measuring an inter-terminal voltage. Otherwise, electric shock may result.



When "S-08" is displayed again, the analog 2 input gain (L-05) and analog 2 input offset (L-06) are changed automatically. Press the [MONI/FNC] key to display the monitoring items.

Turn off the inverter power after adjustment. Then open the front cover and remove the wire attached between the terminals [AIN2] on the terminal block of printed board <EIP66-Z> and [+10] on the terminal block of printed board <VFC66-Z>, and the wire attached to [G] and [G2] on the terminal block of printed board <EIP66-Z>.

## (2) Input characteristic "4 to 20 mA"

\* Perform adjustment after the adjustment of "(1) Input characteristics "0 to ±10 V" and "0 to 10 V"" described previously.



Press the [MONI/FNC] key to enter the FNC (function selection) mode (LED-FNC lights up).



Select "G-03" with the [↑]/[↓] key and confirm it with the [SET] key.

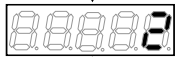

Move the operating digit to the right with the [JOG/→] key and change the value to "2(4-20mA)" using the [↑]/[↓] key. Then confirm the value with the [SET] key.

Printed board  
<EIP66-Z>  
terminal block

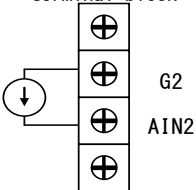

Turn off the inverter power, open the front cover, and then power between the terminals [AIN2], and [G2] on the terminal block of printed board <EIP66-Z>.

Turn ON the SW1 switch while the power of the inverter is turned off.



### **WARNING** [Connecting current power supply]

- Be sure to turn off the inverter before short-circuit of terminals. Otherwise, electric shock may result.
- Be sure to turn off the inverter before using the switch. Otherwise, electric shock may result.

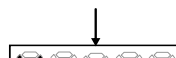

- After turning on the power, and after setting "G-16" and "2" according to the instructions above, use the [↑][↓] keys in the monitor item and select "Vin". The input voltage of analog input (2) will be displayed in monitor "Vin".
- Turn on the current power supply and input 20mA of current to terminal [AIN2].
- This number is displayed.

- Adjust the values of "L-05" so that the values of monitor item "Vin" become "10.00".



After adjustment, disconnect the connected current power supply.

## 5. 3 How to Use Analog Input (2)

Before using the analog input (2), adjust gain and offset as described in the previous section.

Using the analog input (2), an input analog signal can be used as a speed (or frequency) command, torque command or input value to the internal PLC function. This section describes the use of analog input (2) as a speed command and torque command. To use it as an input to the internal PLC function, refer to the VF66 PC Tool manual.

### (1) Using as a speed command

To use analog input as a speed command, the inverter setting parameters shown in the following table need to be set.

## Analog input speed command related settings

Display	Description	Setting band (selection item)	Default	Unit
b-10	Speed commanding place selection	0: Coupled with b-09 1: Analog input (1) [VFC66-Z terminal block AIN1] 2: Console [SET66-Z] 3: Digital communication option 4: Analog input (2) [optional terminal block AIN2] 5: BCD66-Z 6: Analog input (3) [optional terminal block AIN3] 7: Internal PLC function output	0	-
G-04	Analog input (2) upper limit speed	Absolute value of analog input (2) lower limit speed (G-05) to 100.0 <sup>(*)</sup>	100.0	% <sup>(*)</sup>
G-05	Analog input (2) lower limit speed	Negative value of analog input (2) upper limit speed (G-04) to analog input (2) upper limit speed (G-04) <sup>(*)</sup>	0.0	% <sup>(*)</sup>

(\*) A percentage of the maximum speed (setting parameter A-00) is set. For more information about A-00, refer to the operating instructions of VF66 inverter main unit.

- Set b-10 to 4.
- Set G-03 described in Section 5.1 according to the input signal characteristics.

### • For a voltage input of 0 to $\pm 10$ V

A negative value of command input voltage enables reverse operation. As for a speed command, a +10 V input indicates the analog input (2) upper limit speed (G-04) setting, whereas a -10 V input indicates a negative value of the analog input (2) upper limit speed (G-04) setting. The lower limit can be set using the analog input (2) lower limit speed (G-05) setting (see the lower left figure). If the minimum speed (A-01) is not 0, the absolute value of speed command is limited so as to avoid falling below it. In this case, when a command input voltage passes around 0 V, a hysteresis characteristic shown in the lower right figure is observed (the forward minimum speed for starting in the forward operation, and the reverse minimum speed for starting in the reverse operation).

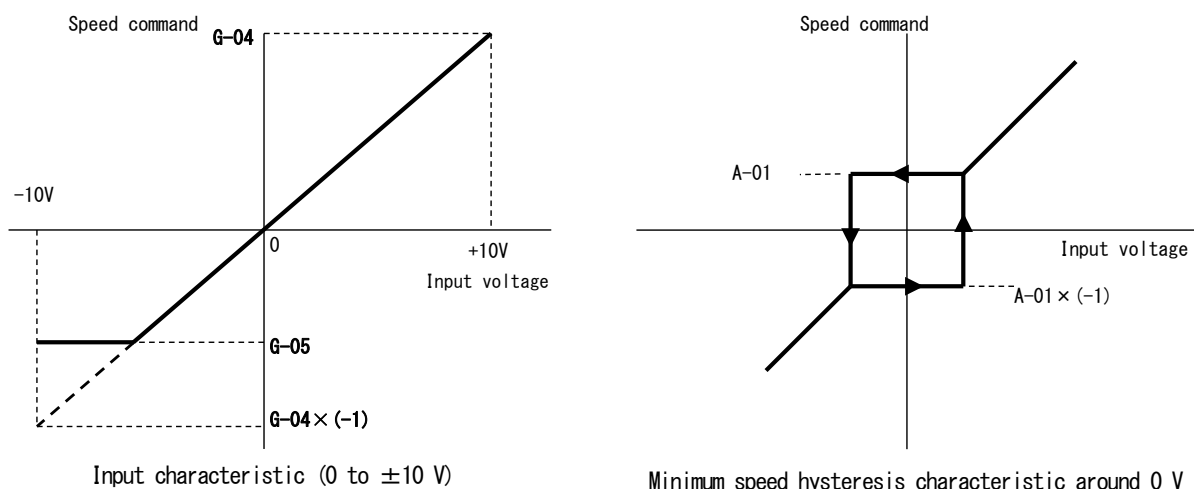
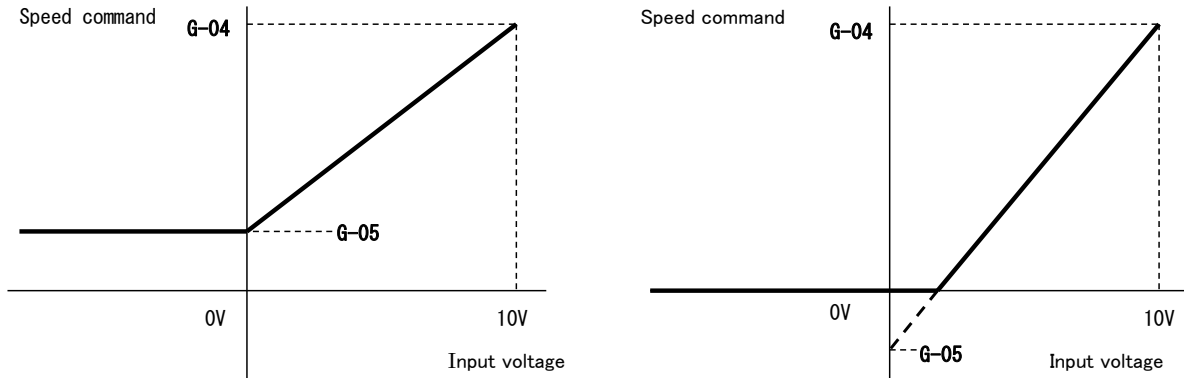

Figure 5. 2 Speed command characteristic of voltage input of 0 to  $\pm 10$  V

### • For a voltage input of 0 to 10 V

As for a speed command, a 0 V input indicates the analog input (2) lower limit speed (G-05) setting, whereas a 10 V input indicates the analog input (2) upper limit speed (G-04) setting. If a negative value is set for

the analog input (2) lower limit speed (G-05), it will be limited to 0 (see the following figure). If the minimum speed (A-01) is not 0, the absolute value of speed command is limited so as to avoid falling below it. Only the forward operation is available for the speed command. Use the reverse operation command to perform reverse operation.



Input characteristic (0 to 10 V) of positive analog input (2) lower limit speed (G-05)      Input characteristic (0 to 10 V) of negative analog input (2) lower limit speed (G-05)

Figure 5. 3 Speed command characteristic of voltage input of 0 to 10 V

• For a current input of 4 to 20 mA

As for a speed command, a 4 mA input indicates the analog input (2) lower limit speed (G-05) setting, whereas a 20 mA input indicates the analog input (2) upper limit speed (G-04) setting. If a negative value is set for the analog input (2) lower limit speed (G-05), it will be limited to 0 (see the following figure). If the minimum speed (A-01) is not 0, the absolute value of speed command is limited so as to avoid falling below it. Only the forward operation is available for the speed command. Use the reverse operation command to perform reverse operation.

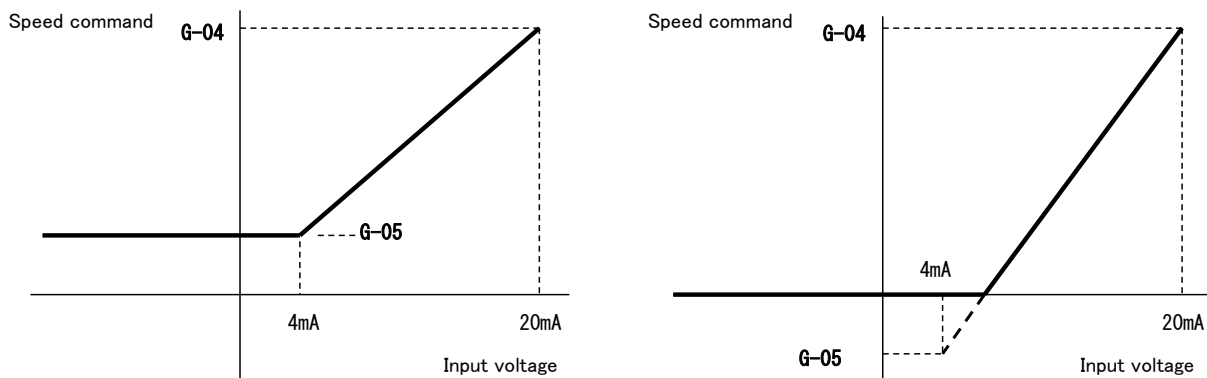

Input characteristic (4 to 20 mA) of positive analog input (2) lower limit speed (G-05)      Input characteristic (4 to 20 mA) of negative analog input (2) lower limit speed (G-05)

Figure 5. 4 Speed command characteristic of current input of 4 to 20 mA

(2) Using as a torque command

To use analog input as a torque command, the inverter setting parameters shown in the following table need to be set.

\* Torque command is unavailable in the V/f mode.

\* The current input characteristic of 4 to 20 mA cannot be used as a torque command. Only the 0 to  $\pm 10$  V input characteristic can be used.

#### Inverter setting parameters related to analog input torque command

Display	Description	Setting band (selection item)	Default	Unit
i-08	Torque command input place selection	0: Analog input (1) [VFC66-Z terminal block AIN1] 1: Analog input (2) [optional terminal block AIN2] 2: Digital communication option 3: Internal PLC function output	1	-
i-09	Analog input torque command gain	50.0 to 200.0	150.0	%

- Set i-08 to 1.
- Set G-03 described in Section 5.1 to 0. Only the 0 to  $\pm 10$  V input characteristic can be used.

As for a torque command, a +10 V input indicates a negative value of the analog input torque command gain (i-09) setting, whereas a -10 V input indicates a positive value of the analog input torque command gain (i-09) setting (see the right figure).

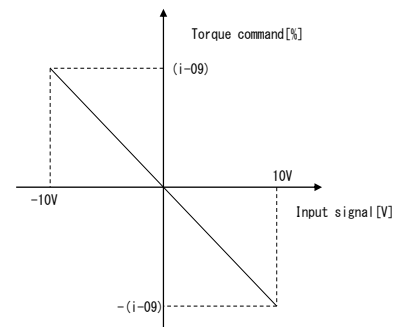

Figure 5.5 Analog input - torque command characteristic

## 5.4 Analog Output (2)

Using the analog output (2) function, internal variables, such as output voltage or speed of inverter and output of internal PLC function, can be output from the EIP66-Z board terminal as an analog signal. An analog signal is output to the terminals "AOT2" and "G2" on the terminal block TB1. The output value can be selected using the inverter setting parameter G-09 shown in the following table. Read also the operating instructions of VF66 inverter main unit. For the internal PLC function, refer to the VF66 PC Tool manual.

Before using the analog output (2) function, adjust gain and offset as described in the following section.

#### Analog output related setting

Display	Description	Setting band (selection item)	Default	Unit
G-09	Analog output (2) characteristics selection	0: Output voltage 1: Output current 2: Torque command (induction motor/ED motor vector mode) Torque output (V/f mode) 3: Motor speed (induction motor/ED motor vector mode) Output frequency (V/f mode) 4: Speed command (induction motor/ED motor vector mode) Output frequency command (V/f mode) 5: Internal PLC output 6: Calibration 7: Internal monitor	1	-

### Analog output selected by G-09

G-09	Selection item	Output voltage
0	Output voltage	7.5 V/200 V (200 V class) 7.5 V/400 V (400 V class)
1	Output current	5 V/inverter rated current
2	Torque command (induction motor/ED motor vector mode) Torque output (V/f mode)	5 V/100 %
3	Motor speed (induction motor/ED motor vector mode) Frequency (V/f mode)	10 V/maximum speed (A-00) 10 V/maximum frequency (A-00)
4	Motor speed command (induction motor/ED motor vector mode) <sup>(*)</sup> Frequency command (V/f mode) <sup>(*)</sup>	10 V/maximum speed (A-00) 10 V/maximum frequency (A-00)
5	Internal PLC output <sup>(*)</sup>	5 V/20000 (100 %) <sup>(*)</sup>
6	Calibration	5 V output
7	Internal monitor	-

(\*) A value obtained after acceleration and deceleration control. For more information, refer to the operating instructions of VF66 inverter main unit.

(\*) With internal PLC output selected, the output register o00009 value is output at the 5 V/20000 rate by the internal PLC function. For more information, refer to the VF66 PC Tool manual.

The analog output (2) is made to the terminals "AOT2" and "G2" on the EIP66-Z board terminal block TB1 as shown in the following figure.

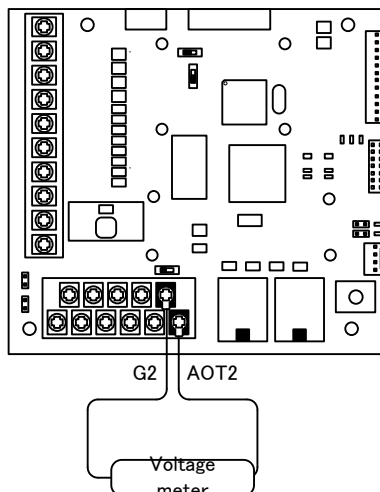

Figure 5. 6 Analog output (2) connection example

## 5. 5 Analog Output (2) Gain/Offset Adjustment

Before using the analog output (2), adjust gain and offset. Perform the adjustment at room temperature (25 °C).

Before adjusting gain and offset for the analog output (2), adjust gain and offset for the analog input (1) of VF66 inverter main unit. For how to adjust gain and offset for the analog input (1), refer to the operating instructions of VF66 inverter main unit. The gain and offset for the analog input (1) are adjusted prior to shipment; therefore, further adjustment is not necessary in normal cases.

**Inverter setting parameters related to analog output (2) gain/offset adjustment**

Display	Description	Setting band (selection item)	Default	Unit
L-09	Analog output (2) gain	50.0 to 150.0	100	%
L-10	Analog output (2) offset	-50.0 to 50.0	0	%
S-09	Analog output (2) adjustment	1: Analog output (2) offset adjustment 2: Analog output (2) gain adjustment	-	-

• Analog output (2) gain/offset adjustment procedure

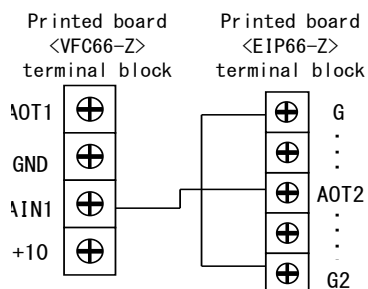

Turn off the inverter power, open the front cover and then make a short-circuit between the terminal block [AOT2] of printed board <EIP66-Z> and terminal block [AIN1] of printed board <VFC66-Z>.

Make a short-circuit between terminal block [G] and [G2] of printed board <EIP66-Z>.

**CAUTION** [Short-circuit of terminals]

- Be sure to turn off the inverter power before short-circuiting terminals. Otherwise, electric shock may result.



After turning off power, press the [MONI/FNC] key to enter the FNC (function selection) mode (LED-FNC lights up).



- Turn on the power and then press the [MONI/FNC] key to enter the FNC (function selection) mode (LED-FNC lights up). After that, select "b-17" using the [JOG/→]/[↑]/[↓] key and confirm it with the [SET] key.



- Change the value to "0" using the [JOG/→]/[↑]/[↓] key and confirm it with the [SET] key.



- "b-17" is displayed again.



- Select "G-09" using the [JOG/→]/[↑]/[↓] key and confirm it with the [SET] key.

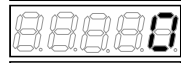

- Change the value to "0" using the [JOG/→]/[↑]/[↓] key and confirm it with the [SET] key.



- "G-09" is displayed again.

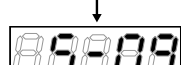

- Select "S-09" using the [JOG/→]/[↑]/[↓] key and confirm it with the [SET] key.



- Change the value to "1040" using the [JOG/→]/[↑]/[↓] key and confirm it with the [SET] key.



- When "S-09" is displayed again, confirm it with the [SET] key.



- Enter "1" using the [JOG/→]/[↑]/[↓] key and confirm it with the [SET] key.



- "S-09" is displayed again

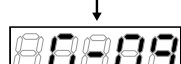

- Select "G-09" using the [JOG/→]/[↑]/[↓] key and confirm it with the [SET] key.



- Change the value to "6" using the [JOG/→]/[↑]/[↓] key and confirm it with the [SET] key.



- "G-09" is displayed again.

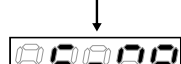

- Select "S-09" using the [JOG/→]/[↑]/[↓] key and confirm it with the [SET] key.



- Change the value to "1040" using the [JOG/→]/[↑]/[↓] key and confirm it with the [SET] key.



- When "S-09" is displayed again, confirm it with the [SET] key.



- Enter "2" using the [JOG/→]/[↑]/[↓] key and confirm it with the [SET] key.



- When "S-09" is displayed again, the analog 1 input gain (L-09) and analog 1 input offset (L-10) are changed automatically.

- Press the [MONI/FNC] key to display the monitoring items.

Turn off the inverter power after adjustment. Then open the front cover and remove the wire attached between the terminals [AOT2] on the terminal block of printed board <EIP66-Z> and [AIN1] on the terminal block of printed board <VFC66-Z>, and the wire attached to [G] and [G2] on the terminal block of printed board <EIP66-Z>.

# CHAPTER 6 PG Input/Output Function

The PG input/output function is used to drive the inverter based on the signals of motor rotor magnetic pole position or speed detected by the sensor (PG). The PG input/output function is used in the VF66 inverter induction motor vector mode and ED motor vector mode. PG supports only the 12 V complementary output. For PG selection and inverter mode change, refer to the operating instructions of VF66 inverter main unit.

## 6. 1 PG Input Signal

To use the PG input/output function, the inverter setting parameter shown in the following table needs to be set appropriately according to the inverter operation mode and PG specifications to use. Read also the operating instructions of VF66 inverter main unit.

\* PG signal input becomes available with the switch SW3 on the EIP66-Z board turned on.

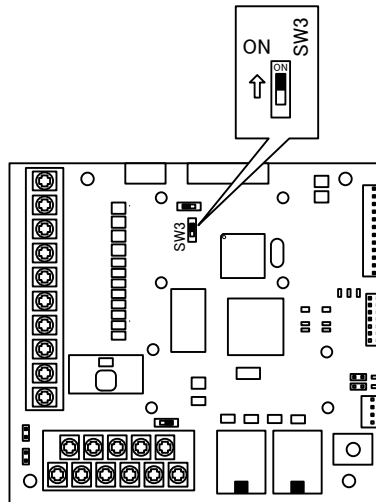

Figure 6. 1 PG input signal switch

### Inverter setting parameter for PG input signal setting

Display	Description	Inverter mode	Setting band (selection item)	Default	Unit
A-10	PG selection	V/f mode	(PG not used)	-	-
		Induction motor vector mode	0: S mode, sensorless drive (PG not used) 1: V mode, drive with PG (A, B phase input)	0	-
		ED motor vector mode	0: S mode, sensorless drive (PG not used) 1: V mode, drive with PG (A, B, Z phase input) <sup>(*1)</sup> 2: P mode, drive with PG (A, B, U, V, W phase input) 3: RL mode, drive with resolver (resolution 10 bit) <sup>(*2)</sup> 4: RH mode, drive with resolver (resolution 12 bit) <sup>(*2)</sup>	0	-

(\*1) For a special motor.

(\*2) Another option is required.

(1) Induction motor vector mode

Set the setting parameter A-10 shown in the above table to 1 and connect a PG wire to the terminal on the EIP66-Z board terminal block TB2 as shown in the following figure (because the terminals U/Z, V and W on TB2 are unused, do not connect to these terminals).

A recommended cable for PG wire is CO-SPEV-SB(A) 3P×0.5SQ (manufactured by Hitachi Metals).

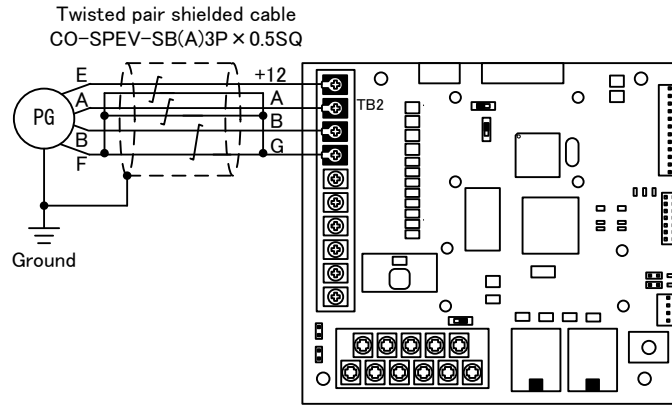

Figure 6. 2 PG wire connection of induction motor

(2) ED motor vector mode

Set the setting parameter A-10 shown in the above table to 2 and connect a PG wire to the terminal on the EIP66-Z board terminal block TB2 as shown in the following figure (because 1 of A-10 is prepared for a special motor, do not select it in normal cases).

A recommended cable for PG wire is CO-SPEV-SB(A) 7P×0.5SQ (manufactured by Hitachi Metals). To connect an ED motor with PG, a straight plug (MS3106B-20-29S) and cable clamp (MS3057-12A) (manufactured by Japan Aviation Electronics Industry) are required.

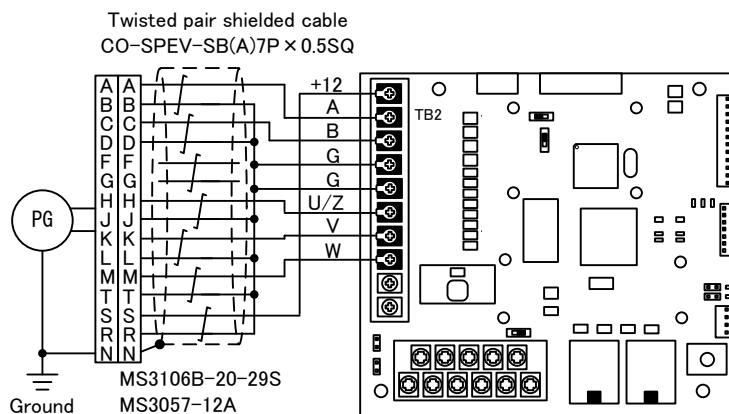

Figure 6. 3 PG wire connection of ED motor



## WARNING [Wiring]

- Be sure to turn off the inverter power before performing PG wiring. Otherwise, electric shock/injury/failure/malfunction may result.
- Never connect the G terminal to a ground. Otherwise, failure/damage may result.
- To connect PG, be sure to connect the ground terminal of PG to a ground. Otherwise, failure/damage may result.



## WARNING [Switches]

- Be sure to turn off the inverter power before turning the switch. Otherwise, electric shock/injury/failure/malfunction may result.

### 6. 2 PG Output Signal

A frequency divided PG signal is output from A signal of PG input. The peak value is approx. 10 V, and duty ratio is one to one. Turning SW2 of EIP66-Z to 3 outputs 1/4 frequency divided PG signal, whereas turning it to 1 outputs 1/2 frequency divided PG signal. Turn the switch according to intended use.

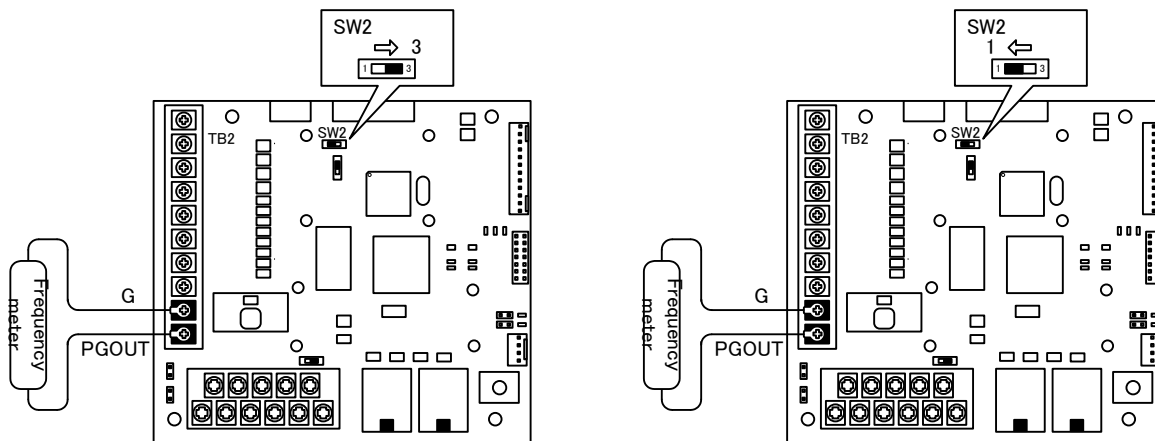

(a) 1/4 frequency divided PG output

(b) 1/2 frequency divided PG output

Figure 6. 4 PG output



## WARNING [Wiring]

- Be sure to turn off the inverter power before performing terminal wiring. Otherwise, electric shock/injury/failure/malfunction may result.
- Never connect the G terminal to a ground. Otherwise, failure/damage may result.

# CHAPTER 7 EtherNet/IP Communication Function

## 7. 1 EtherNet/IP Connection

To connect EIP66-Z to the EtherNet/IP network, star connection using a switching hub and daisy chain connection using the EIP66-Z CN3 and CN4 are available.

To use daisy chain connection, EIP66-Z (A or B in Figure 7.1), which works as a relay node in daisy chain, needs to be powered on. If it is powered off or broken, the node connected after the relay node (C in Figure 7.1) becomes unable to perform communication.

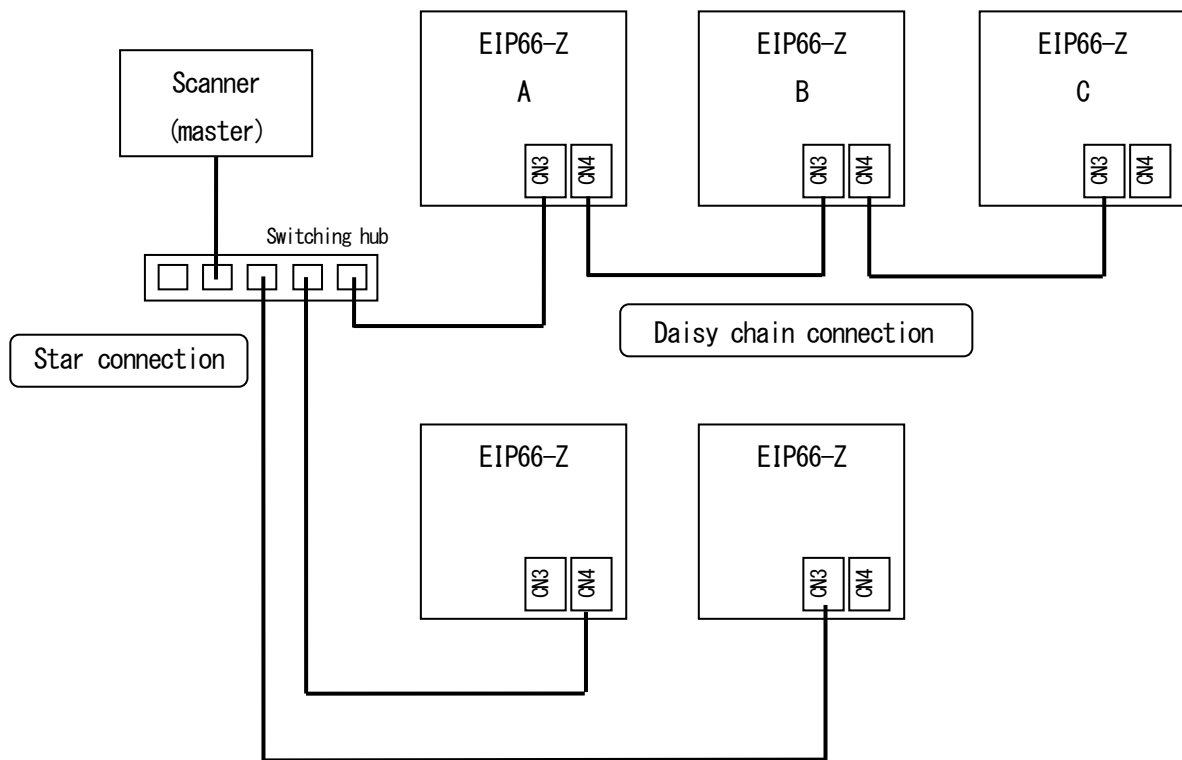

Figure 7. 1 Network connection example

EIP66-Z is equipped with two connectors for EtherNet/IP.  
Either connector can be used to connect to the network.

Use a shielded twisted pair cable (STP) of category 5 (e) or higher that meets the EtherNet/IP standard.  
The length of a cable between nodes, or node and switching hub should be a maximum of 100 m. (100 m is a maximum cable length of the standard. The actual length depends on the specification of used cable.)

## 7. 2 EtherNet/IP Communication Function Setting

---

The EIP66-Z EtherNet/IP communication function allows users to input a command related to operation, speed, torque, etc. or make a multifunction input to the VF66 inverter, or monitor the situations including the inverter operation/protection status, current and voltage. In addition, reading/rewriting of inverter settings and reading of traceback data, protection history and monitoring data are available.

For the EtherNet/IP communication functions, refer to “**EIP66-Z Communication Protocol Manual.**” This function can also be used as an input/output signal of the internal PLC function of the VF66 inverter. For the internal PLC function, refer to the VF66 PC Tool manual.



## **TOYODENKI SEIZO K.K.**

---

<https://www.toyodenki.co.jp/en/>

HEAD OFFICE: Tokyo Tatemono Yaesu Bldg, 1-4-16 Yaesu, Chuo-ku,  
Tokyo, Japan ZIP CODE 103-0028

TEL : +81-3-5202-8132 -6

FAX : +81-3-5202-8150

---

In addition, the contents of this the "operating manual" may be changed without a preliminary announcement by specification change of a product etc. Please understand that it may differ from the contents of the "operating manual" enclosed by the model of purchase, and the contents of the "operating manual" posted on our homepage.

Please have a look from our homepage about the newest "operating manual."

TIM050[C]\_20221226